

GRP STORAGE TANKS

W-Tank[®]



W-TANK[®]
MADE FROM RESINS
WITH HIGH CHEMICAL
RESISTANCE



Technical specifications

No. plates	Diameter	Storage tank volumes for different heights in metres										
		H=2	H=3	H=4	H=5	H=5.5a	H=6	H=7	H=8	H=9	H=10	H=11
Units	Ø (m)	(m ³)	(m ³)	(m ³)	(m ³)	(m ³)	(m ³)	(m ³)	(m ³)	(m ³)	(m ³)	(m ³)
6	4.3	29	44	59	73	81	88	103	117	132	147	162
7	5.1	41	61	82	102	112	123	143	163	184	204	225
8	5.8	52	78	104	131	144	157	183	209	235	261	287
9	6.5	66	99	132	165	182	198	231	264	297	330	363
10	7.2	82	122	163	204	224	245	286	326	367	408	449
11	7.9	99	148	197	247	271	296	345	395	444	494	543
12	8.6	117	176	235	294	323	352	411	470	529	587	646
13	9.4	138	207	276	345	379	414	483	551	620	689	758
14	10.1	160	240	320	400	440	480	560	640	720	799	879
15	10.8	184	275	367	459	505	551	642	734	826	918	1,010
16	11.5	209	313	418	522	574	627	731	835	940	1,044	1,149
17	12.3	236	354	472	589	648	707	825	943	1,061	1,179	1,297
18	13.0	264	396	529	661	727	793	925	1,057	1,189	1,322	1,454
19	13.7	294	442	589	736	810	883	1,031	1,178	1,325	1,472	1,620
20	14.4	326	489	653	816	897	979	1,142	1,305	1,468	1,632	1,795
21	15.1	360	540	720	899	989	1,079	1,259	1,439	1,619	1,799	1,979
22	15.9	395	592	790	987	1,086	1,185	1,382	1,579	1,777	1,974	2,172
23	16.6	432	647	863	1,079	1,187	1,295	1,510	1,726	1,942	2,158	2,374
24	17.3	470	705	940	1,175	1,292	1,410	1,645	1,880	2,115	2,349	2,584
25	18.0	510	765	1,020	1,275	1,402	1,530	1,785	2,039	2,294	2,549	2,804
26	18.7	551	827	1,103	1,379	1,517	1,654	1,930	2,206	2,482	2,757	3,033
27	19.5	595	892	1,189	1,487	1,635	1,784	2,081	2,379	2,676	2,974	3,271
28	20.2	640	959	1,279	1,599	1,759	1,919	2,238	2,558	2,878	3,198	3,518
29	20.9	686	1,029	1,372	1,715	1,887	2,058	2,401	2,744	3,087	3,430	3,773
30	21.6	734	1,101	1,468	1,836	2,019	2,203	2,570	2,937	3,304	3,671	4,038
31	22.3	784	1,176	1,568	1,960	2,156	2,352	2,744	3,136	3,528	3,920	4,312
32	23.1	835	1,253	1,671	2,088	2,297	2,506	2,924	3,341	3,759	4,177	4,594
33	23.8	888	1,333	1,777	2,221	2,443	2,665	3,109	3,554	3,998	4,442	4,886
34	24.5	943	1,415	1,886	2,358	2,593	2,829	3,301	3,772	4,244	4,715	5,187
35	25.2	999	1,499	1,999	2,498	2,748	2,998	3,498	3,997	4,497	4,997	5,496
36	25.9	1,057	1,586	2,115	2,643	2,907	3,172	3,700	4,229	4,758	5,286	5,815
37	26.7	1,117	1,675	2,234	2,792	3,071	3,350	3,909	4,467	5,026	5,584	6,142

Technical specifications

No. plates	Diameter	Storage tank volumes for different heights in metres										
		H=2	H=3	H=4	H=5	H=5.5a	H=6	H=7	H=8	H=9	H=10	H=11
Units	Ø (m)	(m³)	(m³)	(m³)	(m³)	(m³)	(m³)	(m³)	(m³)	(m³)	(m³)	(m³)
38	27.4	1,178	1,767	2,356	2,945	3,239	3,534	4,123	4,712	5,301	5,890	6,479
39	28.1	1,241	1,861	2,482	3,102	3,412	3,722	4,343	4,963	5,584	6,204	6,824
40	28.8	1,305	1,958	2,610	3,263	3,589	3,916	4,568	5,221	5,874	6,526	7,179
41	29.5	1,371	2,057	2,743	3,428	3,771	4,114	4,800	5,485	6,171	6,857	7,542
42	30.3	1,439	2,159	2,878	3,598	3,957	4,317	5,037	5,756	6,476	7,195	7,915
43	31.0	1,508	2,263	3,017	3,771	4,148	4,525	5,279	6,034	6,788	7,542	8,296
44	31.7	1,579	2,369	3,159	3,948	4,343	4,738	5,528	6,317	7,107	7,897	8,686
45	32.4	1,652	2,478	3,304	4,130	4,543	4,956	5,782	6,608	7,434	8,260	9,086
46	33.2	1,726	2,589	3,452	4,315	4,747	5,179	6,042	6,905	7,768	8,631	9,494
47	33.9	1,802	2,703	3,604	4,505	4,956	5,406	6,307	7,208	8,109	9,010	9,911
48	34.6	1,880	2,819	3,759	4,699	5,169	5,639	6,578	7,518	8,458	9,398	10,338
50	35.3	1,954	2,931	3,908	4,885	5,373	5,862	6,839	7,816	8,792	9,769	10,746
51	36.0	2,033	3,049	4,066	5,082	5,590	6,098	7,115	8,131	9,148	10,164	11,181
52	36.7	2,113	3,170	4,227	5,283	5,812	6,340	7,397	8,453	9,510	10,567	11,623
53	37.4	2,195	3,293	4,391	5,488	6,037	6,586	7,684	8,782	9,879	10,977	12,075
54	38.1	2,279	3,419	4,558	5,698	6,267	6,837	7,977	9,116	10,256	11,395	12,535

Tanks in which their Ø and volume can vary depending on design conditions.

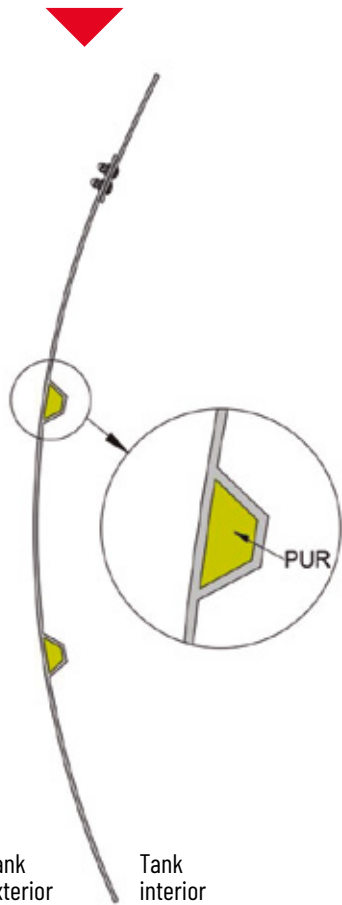
SUPPLY KIT | STORAGE TANK

- Plates.
- Manway.
- Screws - washers - nuts - gaskets.
- Seal with concrete base and sealing primer.
- Assembly instructions.
- Technical brochure and specifications.
- Compliance plan, construction plan for standard floor slab, fasteners and seals.

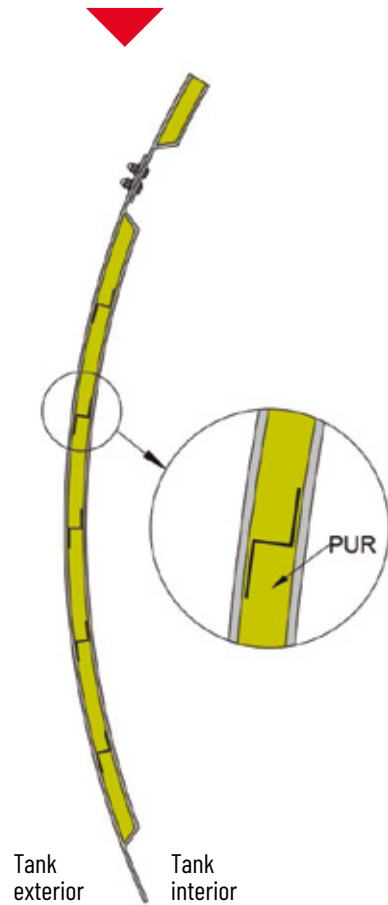


Plate types / cross section

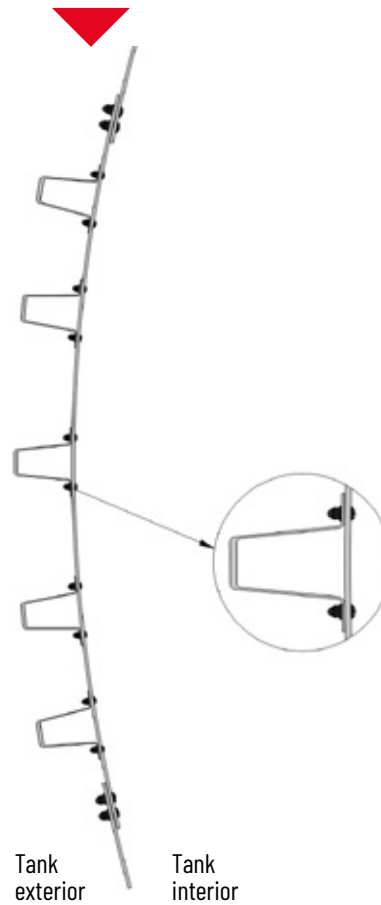
SALAMANCA Plate



BURGOS Plate



VALLADOLID Plate



ADVANTAGES AND USES

SALAMANCA PLATE

- General-purpose tanks

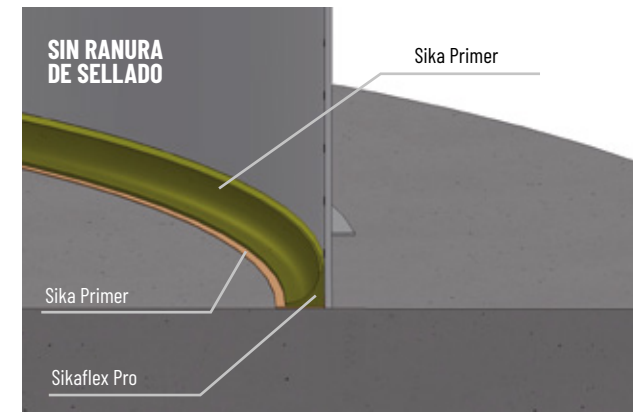
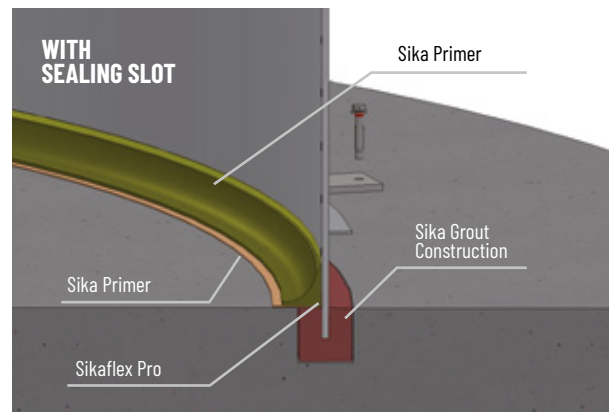
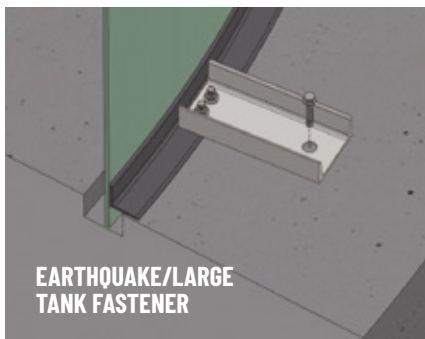
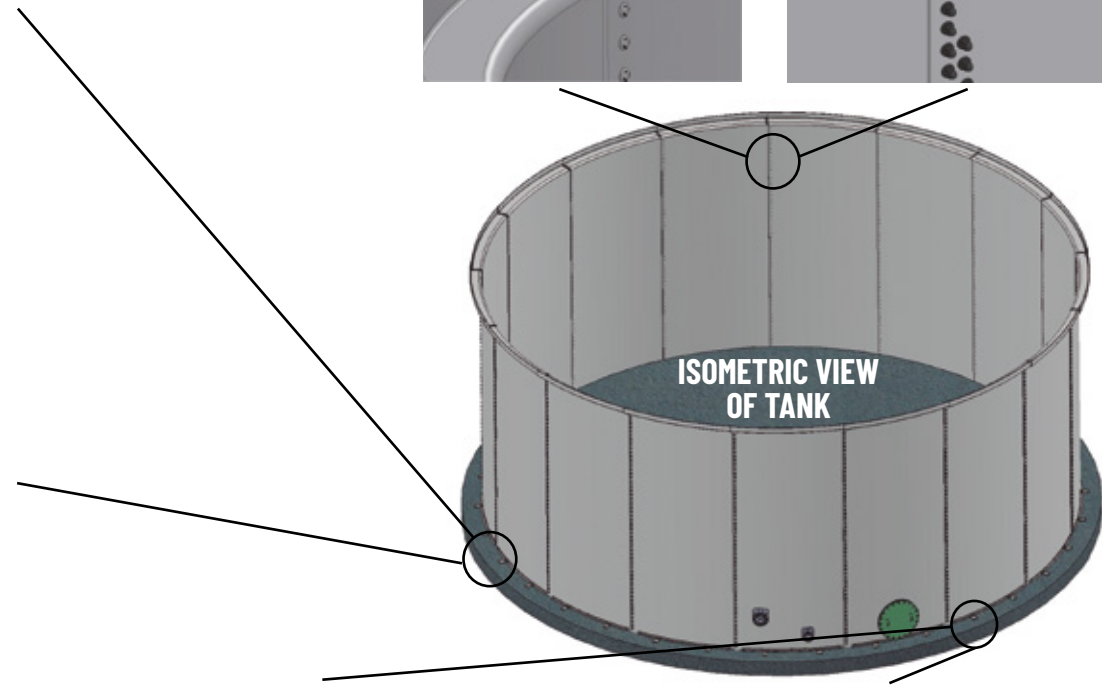
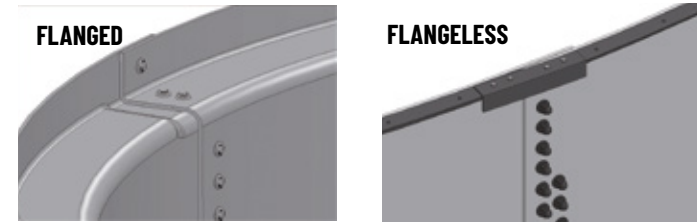
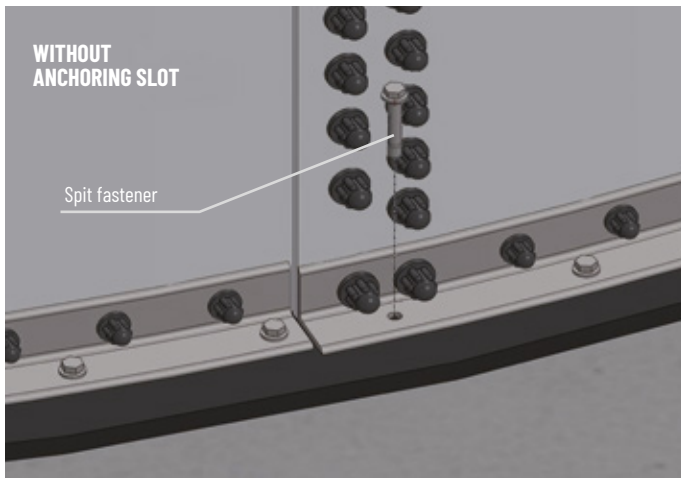
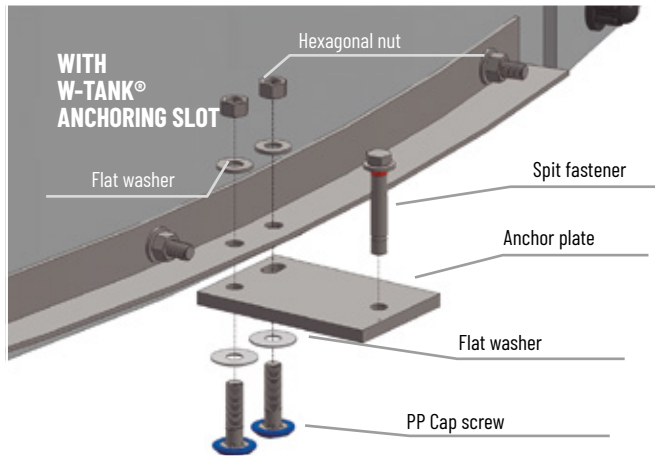
BURGOS PLATE

- Thermally insulated tanks
- PUR - Insulation coefficient 40mm of PUR thickness

VALLADOLID PLATE

- 100% monolithic
- For vertical loads
- Settling tanks
- Allows machining on surface

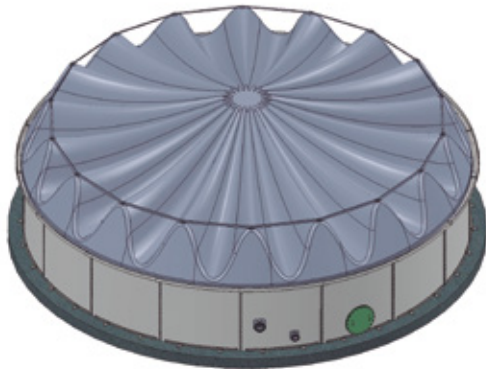
Compliance Plan



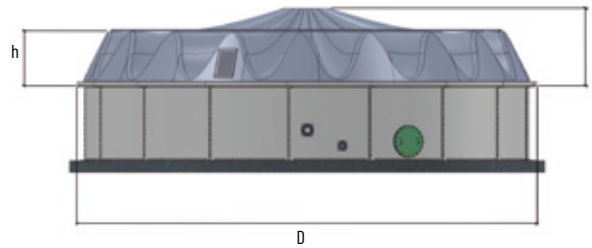
Covers types

HYPAR COVER

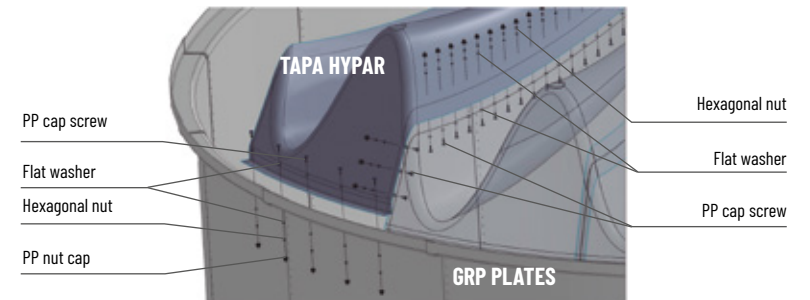
ISOMETRIC VIEW OF TANK



AERIAL VIEW OF TANK

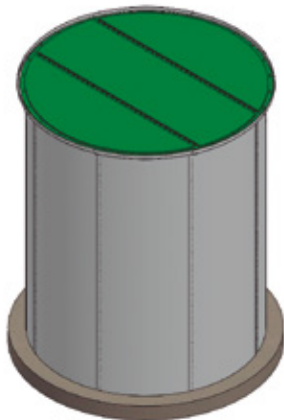


DETAIL OF SCREWS ON HYPAR COVER



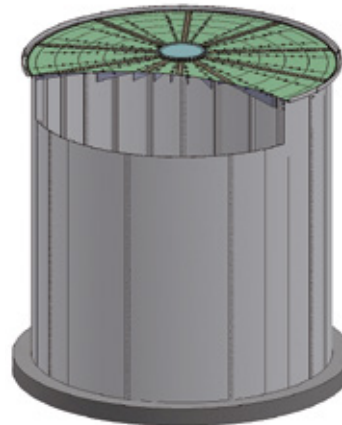
OTHER COVERS

FLAT



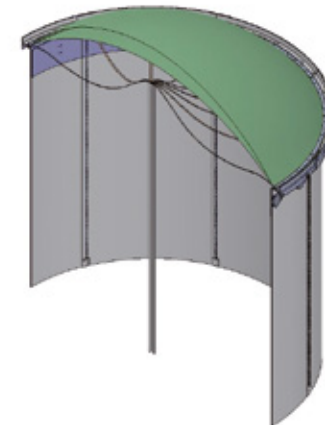
ISOMETRIC VIEW OF TANK

CONICAL



ISOMETRIC VIEW OF TANK

MEMBRANE/GASHOLDER



ISOMETRIC VIEW OF TANK

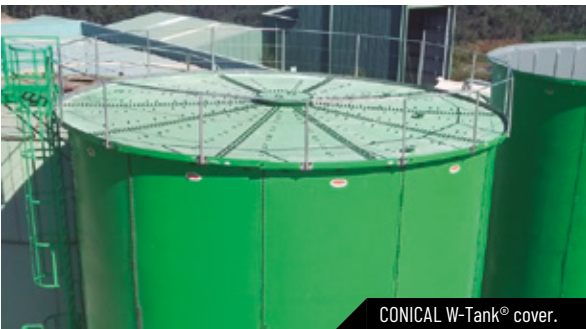
Cover Technical specifications



HYPAR W-Tank® cover.



FLAT W-Tank® hermetic cover for digesters



CONICAL W-Tank® cover.



MEMBRANE/GASOMETRE W-Tank® cover.

SUPPLY KIT HYPAR AND FLAT COVERS

- Roof components in GRP.
- Fastening brackets for attachment to tank.
- Screws - washers - nuts.
- Structural components.
- Assembly instructions.
- Technical brochure and specifications.
- Compliance plan, fasteners and seals.

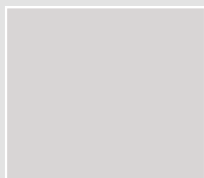
HYPAR model	HYPAR (m)
G2 D4,3	4.6
G3 D5,1	5.4
G3 D5,8	6.1
G12 D6,5	6.8
G12 D7,2	7.5
G12 D7,9	8.2
G15 D8,6	8.9
G15 D9,4	9.7
G15 D10,1	10.4
G18 D10,8	11.1
G18 D11,5	11.8
G21 D12,3	12.6
G21 D13,0	13.3
G21 D13,7	14.0
G25 D14,4	14.7
G25 D15,1	15.4
G25 D14,4	16.2
G25 D16,6	16.9
G25 D17,3	17.6
G30 D18,0	18.3
G30 D18,7	19.0
G30 D19,5	19.8
G30 D20,2	20.5
G30 D20,9	21.2
G35 D21,6	21.9
G35 D22,3	22.6
G35 D23,1	23.4
G35 D23,8	24.1
G35 D24,5	24.8

G indicates the number of segments on the HYPAR cover. Larger Ø available upon request

- Types of flat cover fastening:
 - Standard, cover screwed to tank. Seamless bolted joint.
 - Seal between joints and fastening to tank.
 - 5-20 mbar pressure, recommended for digester tanks.
- Quotations for roofs subject to client specifications, load to be supported, installation of stirrers, strainers, walkways and other project components.
- We supply tarpaulin and mesh covers for special purposes.

Features

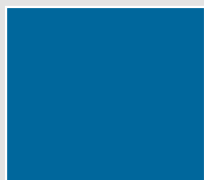
COLOURS



STANDARD COLOUR
LIGHT GREY
RAL 7035



YELLOW GREEN
RAL 6018



LIGHT BLUE
RAL 5012



MOUSE GREY
RAL 7005

(Colors are approximate to RAL table)

- W-Tank® storage tanks and covers are made in RAL 7035 **LIGHT GREY** as standard. Another 3 colours are available as optional extras: **MOUSE GREY**, **YELLOW GREEN** and **LIGHT BLUE**.

- Upon request, we can manufacture tanks in any colour from the RAL chart.



W-Tank® installation

ADVANTAGES

- Excellent resistance to corrosion and rust.
- Very lightweight.
- Easy to transport.
- Installation available all over the world.
- Tanks may be buried.
- Minimal construction time.
- Demountable and reusable.
- Minimal maintenance required.
- Easy to install accessories.

APPLICATIONS

- Wastewater.
- Drinking water.
- Desalination.
- Bulk dry goods.
- Agriculture.
- Waste.
- Settling tanks.
- Separations in existing tanks.
- Biogas.
- Food.
- Chemical products (Consult Compatibility Table).

Manufacturing process



W-Tank® dispatch area. Factory Toro Equipment in Villavaquerín -Spain

DELIVERY

- W-Tank® plates are supplied in **metallic or wooden packaging**, facilitating mass delivery.
- Storage tanks, settling tanks and covers **can be transported in 20-foot and 40-foot high-cube shipping containers**, as well as in conventional lorries.
- This **ease of transport** allows us to ship **W-Tank® all over the world**.



W-Tank® storage tank with 36 Salamanca plates, H=5m, D=25m and 2,534m³ capacity transported in a 40-foot container.



W-Tank® with H=11m, D=13.2m and 1,505m³ capacity transported in a lorry.

EASY TO ASSEMBLE

- W-Tank® storage and settling tanks are quick and **easy to assemble and require few logistical resources**.
- The product **can be disassembled and moved for use in a different location**.
- **Assembly instructions** are provided.



WATCH VIDEO

Manufacturing process

FLEX MOLDING

This manufacturing process uses cutting edge technology in the composites sector.

Flex moulding offers a number of advantages over traditional lamination and infusion processes:

- Improved mechanical properties, due to increased fibre content.
- Improved product performance, due to reduced weight as a result of lower quantities of resin used.
- Environmentally friendly process. Components are constructed using closed moulds, improving environmental conditions and workspace quality. This also allows us to reduce CO2 emissions.
- This process allows us to control the thickness and orientation of the materials.



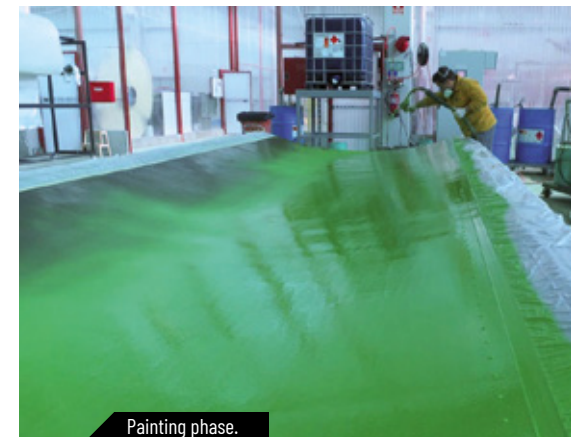
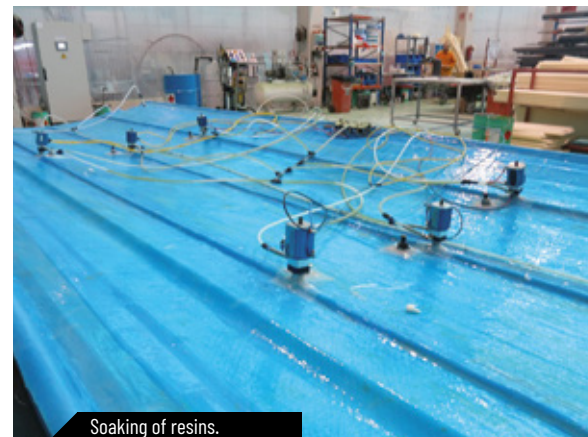
CUTTING EDGE
TECHNOLOGY



LOW CO2
EMISSIONS



CONTROLLED
THICKNESS



Material specifications

PLATE COMPOSITION

Outer chemical barrier:

- 600µm isophthalic gel coat (nautical quality) with UV stabiliser.

Laminate:

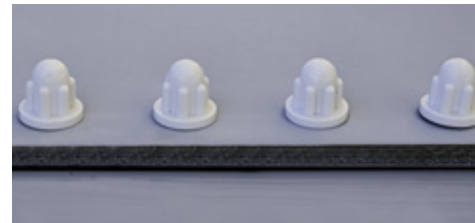
- Purpose-built balanced multi-axial fibreglass
- Surfacing veil, high absorptive capacity.
- Specific resin for flex moulding vacuum infusion process in vinylester quality.
- Food-grade resin.

Interior finish:

- Colourless with isophthalic resin or vinylester finish.

OTHER MATERIALS USED

- **Standard-format Toro Bolt screws:** polypropylene inner tank head, galvanised steel structure and polypropylene exterior cap. Other properties optional.
- **EPDM (Ethylene Propylene Diene Monomer)** elastomer gasket, offering excellent resistance to abrasion and wear. Good resistance to atmospheric, acidic and alkaline agents, and to chemical products in general. The working temperature oscillates between -40°C and 130°C.
- **Screw and tank seals according to project specifications or tank contents.** Sealed with polyurethane-based mastic or nylon gasket.
- **Nylon/EPDM gasket,** working temperature range -40°C to 90°C, fatigue strength, high shock absorption, good sliding properties, excellent resistance to wear and self-extinguishing.
- **Internal polyurethane foam (PUR) cores** as in the Burgos and Salamanca plates.



POTABLE WATER



Certified to
NSF/ANSI/CAN 61

GRP chemical resistance table (EN ISO 175)

Fluid	Isophthalic resin	Vinylester resin
Water pH Drinking water	● 3-9	● 2-13
Sea water	● 50°C	● 95°C
Drinking water	● 76°C	● 111°C
Hydrochloric Acid Concentrate	● 25°C	● 25°C
Sulphuric Acid 10%	● 30°C	● 90°C
Sulphuric Acid 60%	●	● 75°C
Acetic Acid 10%	● 40°C	● 95°C
Acetic Acid 25%	●	● 95°C
Nitric Acid 10%	●	● 60°C
Nitric Acid 30%	●	● 40°C
Formic Acid 10%	● 30°C	● 65°C
Ácido Fórmico 50%	●	● 50°C
Phosphoric acid 20%	● 40°C	● 95°C
Ethanol 100%	●	● 25°C
Sodium hydroxide	●	●
Methanol 100%	●	●
Acerton 10%	●	● 80°C
Hypochlorite 5%	●	● 25°C
Ammonia	●	●
Brine 100%	● 50°C	● 95°C

*For resistance to aggressive chemical products and high temperatures, it is manufactured in vinylester.

*For other types of fluids, please contact us.

● Recommended ● No recommended

Table of mechanical resistance GRP

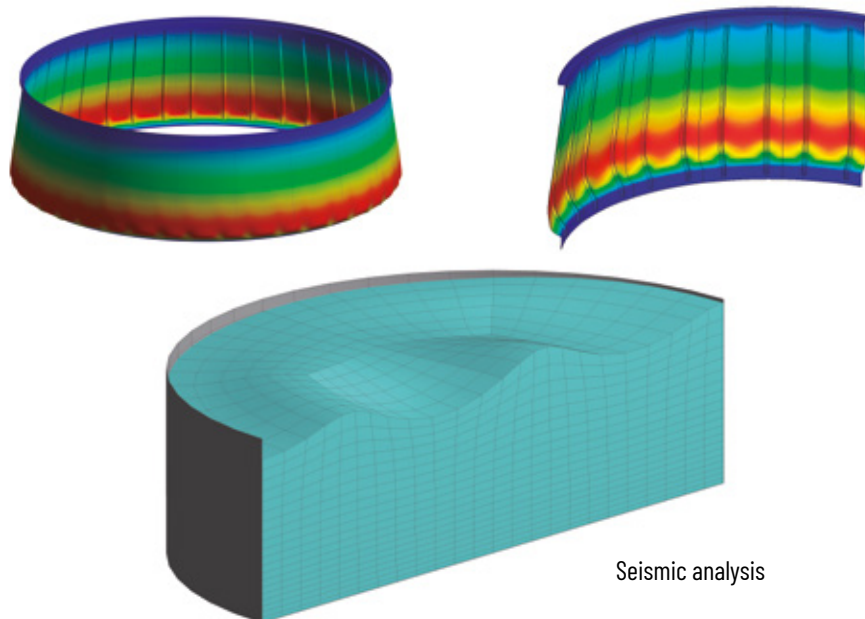
SPECIFICATIONS	STANDARD	VALUE	UNIT
Barcol hardness	EN ISO 53270	≥60	Barcol
Glass mass content	EN ISO 3451-1, Método A	[68.1±2]	%
Resistance to traction	EN ISO 527-4	[460±11]	MPa
Elastic modulus	EN ISO 527-4	[21.5±1.3]	GPa
Shearing deformation	EN ISO 527-4	[2.3±0.07]	%
Flexural modulus	EN ISO 14125	[19.4±1]	GPa
HDT	EN ISO 75-3	Isotática [76±1] / Vinilester [111±2]	°C
Composite density	EN ISO 1183-1, Método A	[2.3±0.2]	t/m ³
H2O absorption (2d)	EN ISO 62, Método 1	≤1	%
Thermal cond. Coef. Burgos	EN ISO 22007-2	0,4511	W/m•K
Thermal transf. coef; Burgos	EN ISO 11357-3	0.02107	W/m•K

* Bending stress (MPa) can be obtained. Varies according to the thickness of the material.

Tests and calculations

QUALITY TESTS

All storage tanks, settling tanks and covers have been analysed and have undergone a number of different quality tests and trials in collaboration:

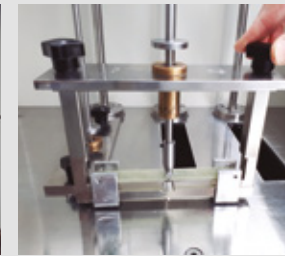


LABORATORY TESTS

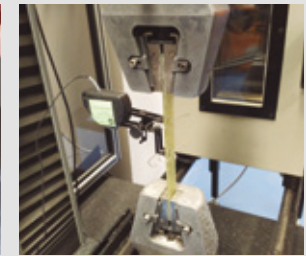
Bending test



HDT test



Traction test



Scanning electron microscope (SEM) test

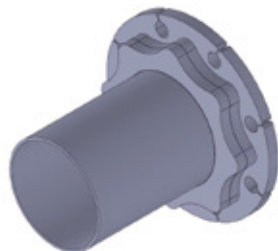


Optional extras

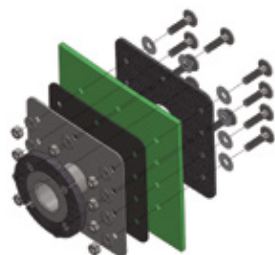
Corrosion resistant ladders/ GRP



Welded GRP Flange



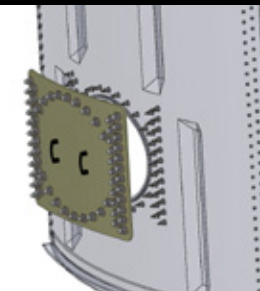
Single flange



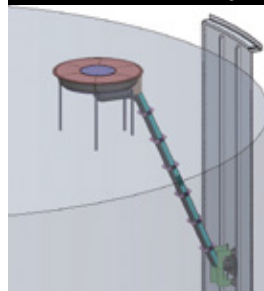
Double flange



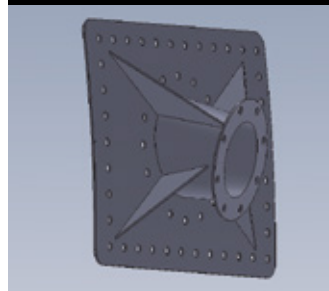
Manway



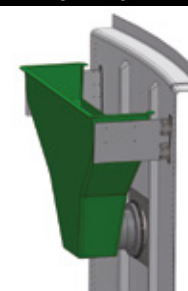
SBR-1900 settling kit



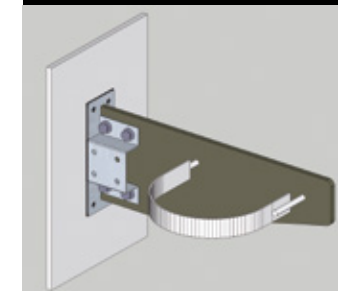
Stirrer bracket



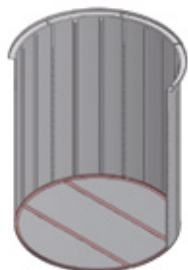
Degassing hopper



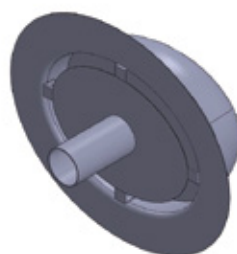
Stainless steel/GRP tube bracket



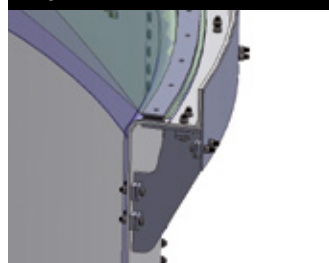
GRP floor



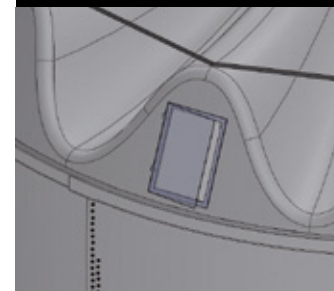
SBR Settling ≤ 90 m³



Fastening system for gasometer and membranes



Access window in cover



Access window in stirrers



Optionals

EQUIPMENT

● Standard equipment ● Optimal equipment

BODY	STORAGE TANK	COVER
Composite material - Isophthalic resin	●	●
Composite material - Vinylester resin	●	●
Connection flanges	●	●
Manhole	●	●
Exterior cage ladders	●	●
Exterior extension ladders	●	●
Exterior spiral ladders	●	●
Interior ladders	●	●
Access walkway	●	●
45x45 window	-	●
Degassing hopper	●	-
SBR Settling kit	●	-
SBR Settling	●	-
Stirrer bracket	●	-
GRP floor	●	-
Stainless steel/GRP tube bracket	●	-
Fastening system for gasholder and membranes	●	●

DOCUMENTS

DOCUMENTS	STORAGE TANK	COVER
Compliance plan - concrete floor construction plan - fasteners and seals*	●	●
Technical brochure and specifications	●	●
Assembly instructions	●	●
Calculation report	●	●
Seismic area sizing	●	●
Wind load sizing	●	●
Snow load sizing	●	●

* Acceleration in OG rock has been taken into consideration.

● Ladder



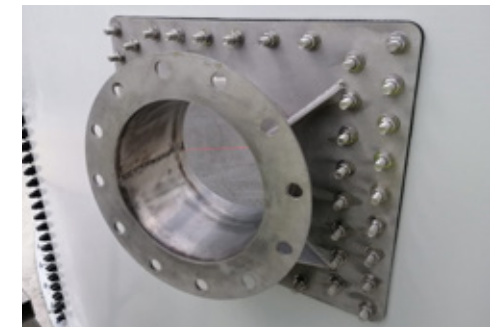
● Connection flanges



● Manhole



● Stirrer bracket



● Estandard equipment ● Optional equipment

CERTIFICATES

CERTIFICATES	STORAGE TANK	COVER
Quality certificate	●	●
Warranty certificate	●	●
Food-grade certificate	●	●
Tests and trials certificate	●	●

COLOUR

COLOUR	STORAGE TANK	COVER
RAL 7035 - Light grey	●	●
RAL 6018 - Yellow green	●	●
RAL 5012 - Light blue	●	●
RAL 7005 - Mouse grey	●	●
Any colour from RAL chart	●	●

ASSEMBLY

ASSEMBLY	STORAGE TANK	COVER
Assembly tools	●	●
Assembly and disassembly	●	●
Assembly supervision	●	●

NOTES:

- Optional equipment is charged extra. Contact us for more information and prices.
- Sizing for seismic areas, snow load and wind load: consult the Technical Department.
- Technical development may lead to changes to some specifications. See toroequipment.com

STORAGE TANKS ADAPTED TO YOUR NEEDS WHAT WE NEED TO KNOW

- Usable tank volume.
- Specify tank contents. E.g. potable water, grain or floric acid.
- Working temperatures.
- Maximum or minimum pH.
- Installation site.
- Geotechnical study.
- Design velocity.
- Seismic zone.
- Snow load.
- Space allowance: diameter or height limitation.
- Undergrounding of the reservoir.
- Installation of options. E.g. cover, flanges or ladders.





Factory Villavaquerín - Valladolid

WORLD REFERENCES

- Algeria
- Argentina
- Australia
- Austria
- Belgium
- Brazil
- Bulgaria
- Canada
- Chile
- China
- Colombia
- Costa Rica
- Croatia
- Dominican Republic
- Ecuador
- Egypt
- Estonia
- Finland
- France
- Germany
- Greece
- Guatemala
- Holland
- Hungary
- Indonesia
- Iran
- Ireland
- Israel
- Italy
- Japan
- Jordan
- Latvia
- Lebanon
- Lithuania
- Luxembourg
- Malaysia
- Mexico
- Montenegro
- Morocco
- Netherlands
- Nicaragua
- Pakistan
- Panama
- Peru
- Philippines
- Poland
- Portugal
- Qatar
- Romania
- Russia
- Saudi Arabia
- Serbia
- Seychelles
- Singapore
- Slovenia
- South Africa
- Spain
- Switzerland
- Thailand
- Trinidad and Tobago
- Tunisia
- Turkey
- UK
- Ukraine
- United Arab Emirates
- United States of America
- Uruguay
- Vietnam

FOUNDED
1989



+34 983 403 047
toro@toroequipment.com
toroequipment.com

FACTORY

Ctra. Nacional VP-3302, km 11
47329 Villavaquerín
Valladolid (Spain)

FACTORY AND OFFICES

C/ Ronda del Sauce 34
47193 La Cistérniga
Valladolid (Spain)



Certified to
NSF/ANSI/CAN 61



INNOVATIVE SME
Valid until Feb 12th 2022



© TORO EQUIPMENT 2021
GRP Storage tanks

W-Tank®